



# **ILJIN Company Profile**

**ILJIN**

# Contents

- 1. Milestone**
- 2. Worldwide locations**
- 3. Long Term Sales Plan**
- 4. Business**
- 5. Customers**

# 1. Milestone

- 
- 1970s**
    - 1978. 12. Established ILJIN Forging(currently ILJIN BEARING)
  - 1980s**
    - 1982. 08. Established Bloxwich Korea(currently ILJIN GLOBAL) as a joint venture company
    - 1986. 01. Established Dong-A Industrial(currently ILJIN Corp.)
  - 1990s**
    - 1994. 01. ILJIN Industrial(currently ILJIN BEARING) started wheel bearing business(Gen.2)
    - 1997. 07. Established ILJIN INDIA
  - 2000s**
    - 2000. 04. **ILJIN Industrial(currently ILJIN BEARING) developed Gen.3 wheel Bearings**
    - 2001. 11. Gen.3 Bearing was selected as the next world-class product by Korean Government
    - 2002. 01. Established ILJIN AUSTRALIA
    - 2002. 10. Established BEIJING ILJIN
    - 2003. 03. Established ILJIN USA and tech center
    - 2005. 11. Established ILJIN SLOVAKIA
    - 2006. 11. Established TIANJIN ILJIN
    - 2008. 02. Established ILJIN AMERICA(currently ILJIN USA SC)
    - 2008. 04. Established ILJIN GmbH(currently ILJIN BEARING GmbH)
  - 2010s**
    - 2010. 09. Established ILJIN ALABAMA
    - 2011. 05. Established BEARING ART
    - 2013. 06. Completion of BEARING ART Young-ju
    - 2014. 09. Established North America R&D Center
    - 2015. 06. Established CHONGQING ILJIN

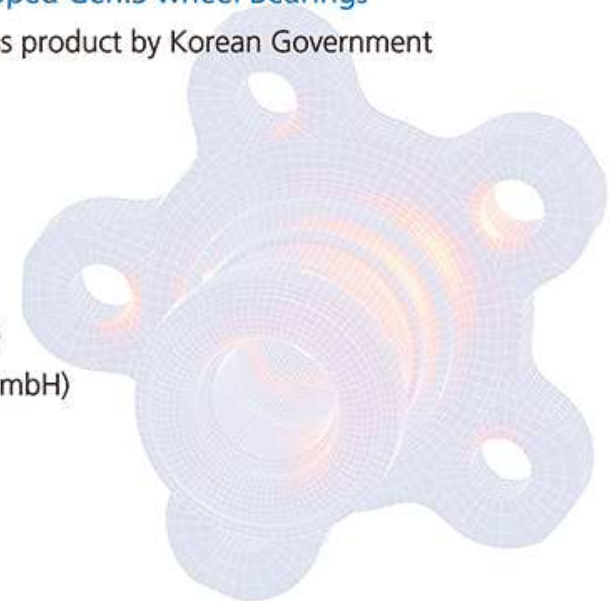

# 2-1. Worldwide locations [South KOREA]



# 2-2. Worldwide locations



1 ILJIN USA



2 ILJIN USA SC



3 ILJIN ALABAMA



4 BEIJING ILJIN



11 ILJIN AUSTRALIA



10 ILJIN BEARING GmbH



9 ILJIN SLOVAKIA



8 ILJIN INDIA



7 YANCHENG Plant



6 CHONGQING ILJIN



5 TIANJIN ILJIN

# 3. Long Term Sales Plan

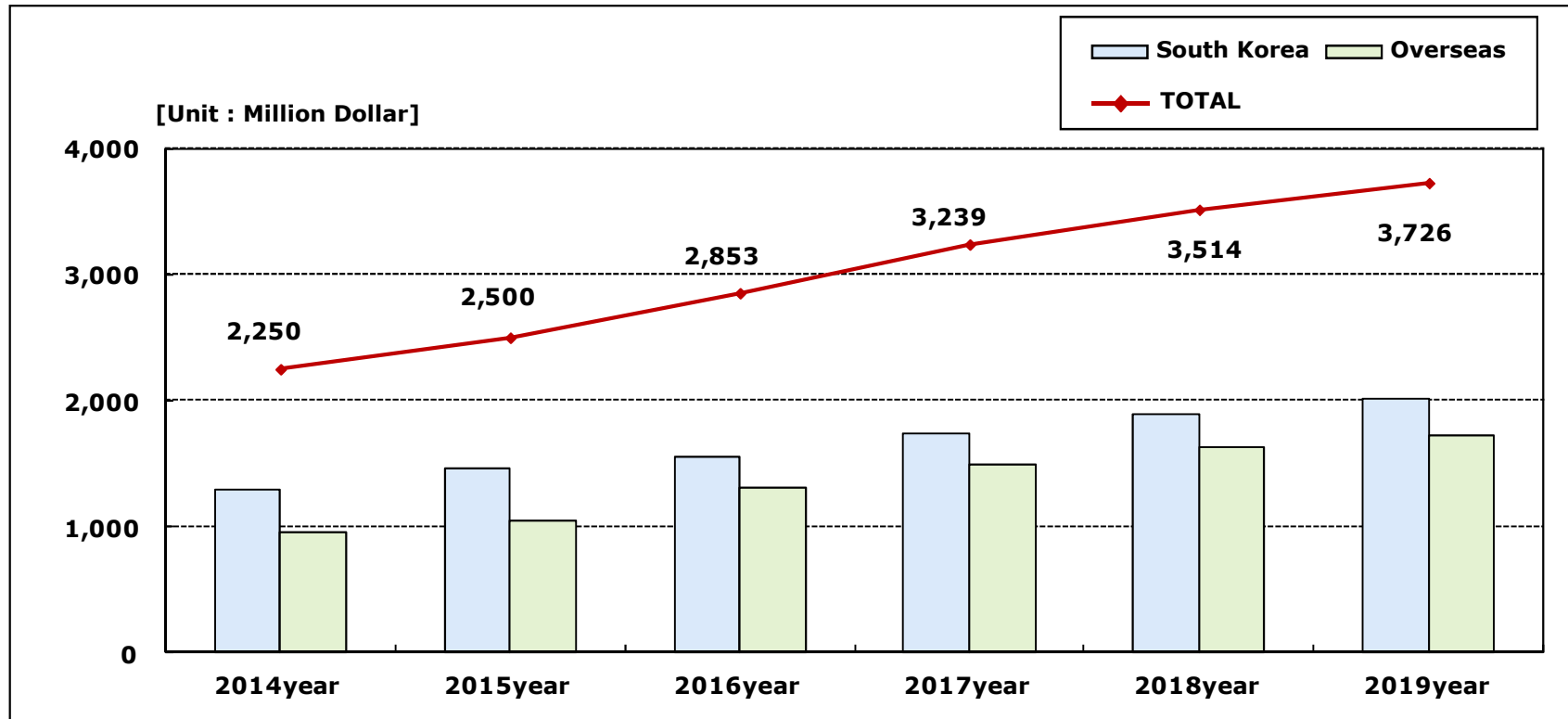

[Unit : Million Dollar]

Section		2014year	2015year	2016year	2017year	2018year	2019year
Sales	South Korea	1,290	1,458	1,546	1,741	1,892	2,012
	Overseas	960	1,042	1,307	1,498	1,622	1,714
<b>TOTAL</b>		<b>2,250</b>	<b>2,500</b>	<b>2,853</b>	<b>3,239</b>	<b>3,514</b>	<b>3,726</b>

# 4. Business

## Hub Unit Bearings

o Ball Bearing



o Tapered Roller Bearing



o Wheel Speed Sensor

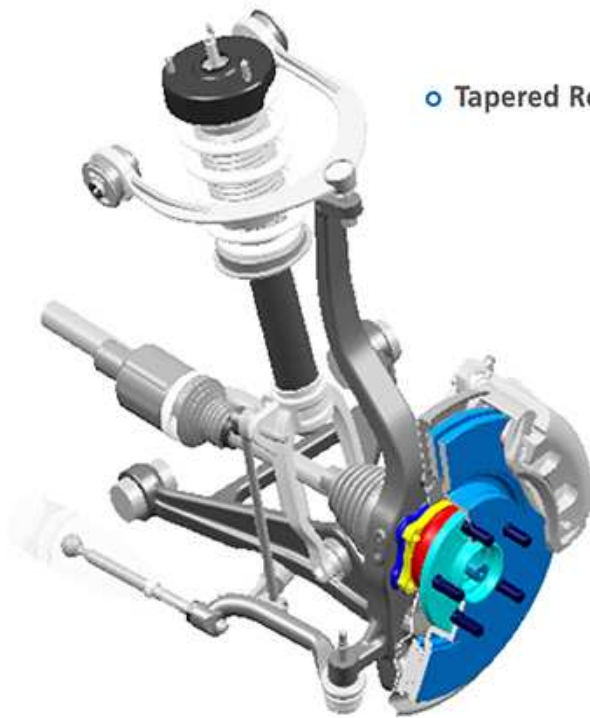

## Bearings for Transmission

- Flange Type Double-Row Tapered Roller Bearing





Gear



- Plastic Cage Tapered Roller Bearing



- Steel Cage Tapered Roller Bearing



Transmission



## Bearings for Axle

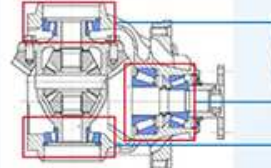

Axle(Front&Rear)

- High Load Tapered Roller Bearing





## Bearings for Industrial



o Large Angular Contact Ball Bearing



o Slewing Bearing(Pitch)



o Slewing Bearing(Yaw)

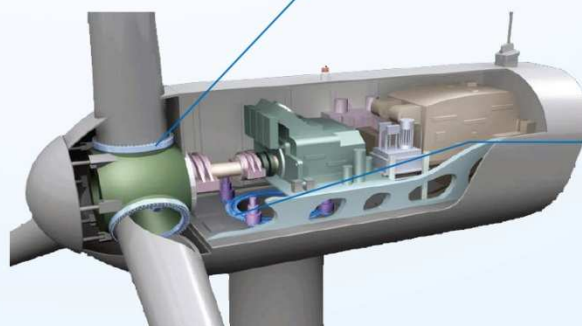

## Suspension and Steering

○ Stabilizer Link



○ Ball Joint



○ Tie Rod End



○ Door Checker



○ UPR ARM



○ AXLE



○ LWR ARM

Steel ARM



AL ARM

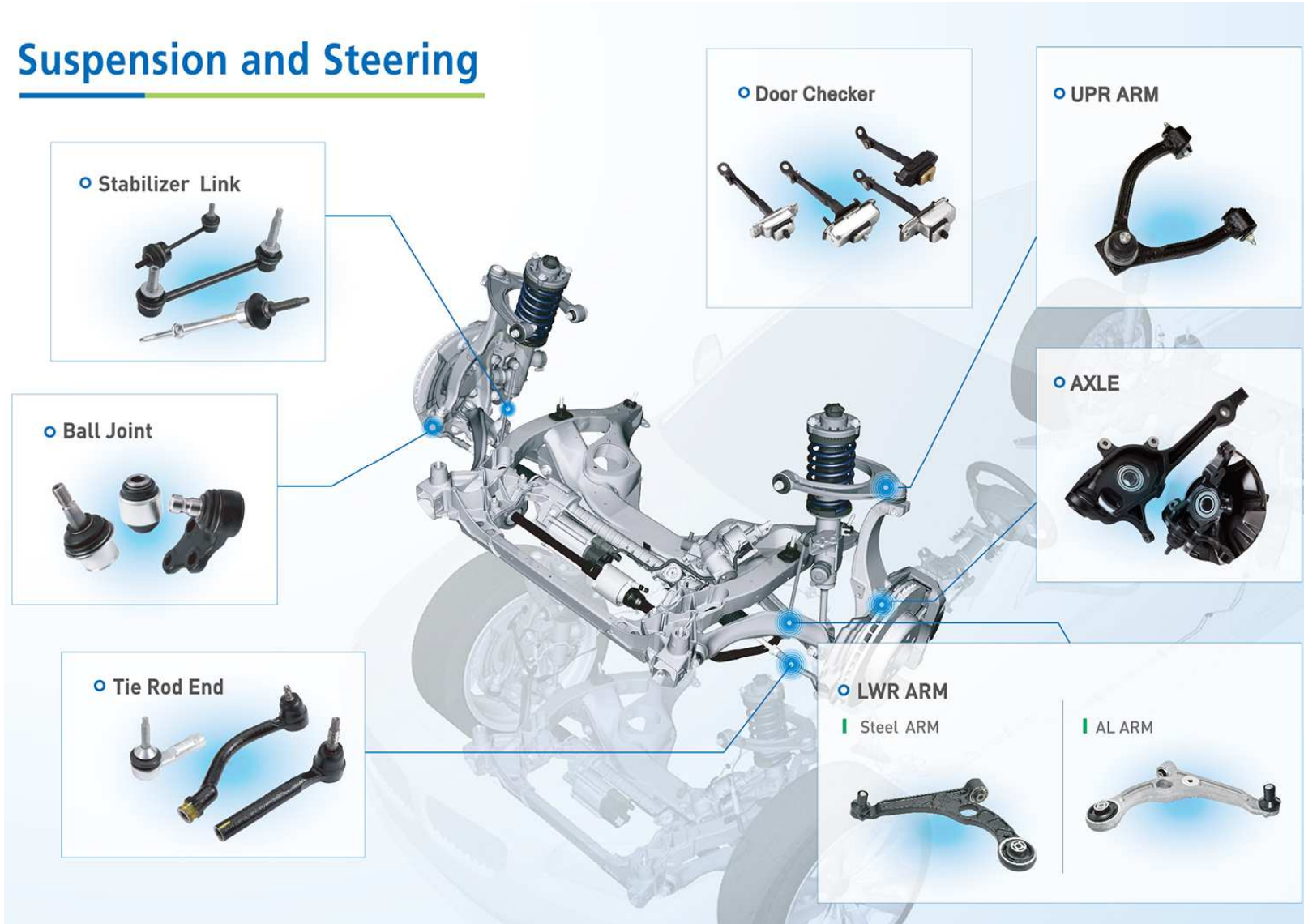

# 5. Customers

## Europe

 Mercedes-Benz Mercedes-Benz	 BMW BMW	 Audi Audi	 Volkswagen Volkswagen	 FIAT FIAT
---	---	---	---	---

## North America

 GM GM	 CHRYSLER CHRYSLER	 FORD FORD	 FEDERAL MOGUL FEDERAL MOGUL	 TIMKEN TIMKEN
---	---	---	---	---

## Republic of Korea & Asia

 HYUNDAI HYUNDAI	 KIA KIA	 GM KOREA GM KOREA	 HYUNDAI MOBIS HYUNDAI MOBIS	 Renault-samsung Renault-samsung
 SHANGHAI GM SHANGHAI GM	 NISSAN NISSAN	 奇瑞汽车 CHERY AUTOMOBILE CHERY AUTOMOBILE	 ISUZU ISUZU	 GEELY GEELY